



SAILING INSTRUCTIONS (SI)
32th MAGIC MARINE INTERNATIONAL OPTIMIST EASTER REGATTA
14 – 17 April 2017
WV Braassemmermeer
Roelofarendsveen, the Netherlands

Version 1.0

The Organizing Authority is the Watersportvereniging Braassemmermeer, in conjunction with the Optimist Club Nederland

1. RULES

- 1.1 The Regatta will be governed by the *rules* as defined in “*The Racing Rules of Sailing*” (RRS).
- 1.2 The prescriptions of the Royal Netherlands Sailing Association (RNSA) will apply. See www.sailing.org/33568.php
- 1.3 RRS Appendix P as amended in SI 27 will apply.
- 1.4 RRS Appendix T will apply
- 1.5 If there is a conflict between languages the English text will take precedence.

2. Disclaimer of liability / Risk statement

Rule 4 of the Racing Rules of Sailing states: “The responsibility for a boat’s decision to participate in a race or to continue racing is hers alone.”

Sailing is by its nature an unpredictable sport and therefore inherently involves an element of risk. By taking part in the event, each competitor, each parent present or not, each coach agrees and acknowledges that:

- a) They are aware of the inherent element of risk involved in the sport and accept responsibility for the exposure of themselves and their boat to such inherent risk whilst taking part in the event;
- b) They are responsible for the safety of themselves and their boat and their property whether afloat or ashore;
- c) They accept responsibility for any injury, damage or loss to the extent caused by their own actions or omissions;
- d) Their boat is in good order, equipped to sail in the event and they are fit to participate;
- e) The provision of a race management team, patrol boats and other officials and volunteers by the event organiser does not relieve them of their own responsibilities;
- f) The provision of patrol boat cover is limited to such assistance, particularly in extreme weather conditions, as can be practically provided in the circumstances;
- g) Their boat is adequately insured.

3. ADVERTISING

In accordance with World Sailing Regulation 20.4 each Optimist class boat will be required to affix to both sides of its hull a decal displaying advertising of the event sponsors.





4. NOTICES TO COMPETITORS

Notices to competitors will be posted on the official Notice Board located at the Regatta Office.

5. CHANGES TO SAILING INSTRUCTIONS

Any change to the SI will be posted on the official Notice Board at least two hours before the start of the race in which it takes effect. Any change to the schedule of races will be posted before 20.00 hrs. on the day before it will take effect.

6. SIGNALS MADE ASHORE

6.1. Signals ashore will be displayed on or near the signal mast in front of the Clubhouse of the Watersportvereniging Braassemmermeer.

When flag AP is displayed ashore "1 minute" is replaced by "not less than 30 minutes" in race signal AP.

7. FORMAT OF RACING

7.1. The regatta will consist of a qualifying series and a final series.

7.1.1. The fleet will be divided into three starting groups (group 1, group 2 and group 3). The starting groups will sail a qualifying series on Friday 14 and Saturday 15 April, followed by final series on Sunday 16 and Monday 17 April 2017. If by the end of racing on Saturday and after the last protest of that day fewer than five races have been completed, there will be no final series, but qualifying series on Sunday.

7.1.2. Initial assignments for the qualifying series will be made on a random basis by the Organizing Authority. Those assignments will be posted for 10:00 hrs. on Friday 14 April 2017.

7.1.3. For the second day and eventually the third day of the qualifying series, boats will be reassigned to starting groups, except if on the first day only one race is completed. If all starting groups have completed the same number of races, boats will be reassigned on the basis of their ranks in the series. If not all groups have completed the same number of races the series score for reassignment will be calculated for those races completed by all starting groups.

7.1.4. Reassignments will be made on a 1, 2, 3, 3, 2, 1 basis.

7.1.5. Assignments will be based on the ranking available at 19:00 hrs. that day, regardless pending protests or requests for redress. Assignments or re-assignments will not be grounds for redress. This changes RRS 62.1(a).

7.1.6. Each day, two hours before the first scheduled start of that day, a list with the classification of the groups will be published on the official notice board and on the event website.

7.2. Boats will be assigned to final series starting groups on the basis of their ranks in the qualifying series. The final series starting groups will be, as nearly as possible, of equal size but so that the Silver group is not larger than the Gold group and so on. Boats with the best qualifying series ranks will race all final series in Gold, boats with the next best qualifying series ranks will race in Silver, the remaining boats will sail in Bronze.

7.3. Different final series groups need not have completed the same number of final races.





8. PROGRAM AND SCHEDULE OF RACES

8.1 The schedule of races is as follows:

Thursday 13 April 2017

18:00 – 20:00 Registration sailors, coach- and support boats

Friday 14 April 2017

8:00 – 11:30 Registration sailors, coach- and support boats
11:00 Opening ceremony 32th Magic Marine Optimist Easter Regatta 2017
11:20 Coach meeting

RACE 1	Group 1 - Yellow	Warning signal 12:55 hrs
	Group 2 – Blue	Warning signal 5 minutes after a valid start of group 1
	Group 3 – Red	Warning signal 5 minutes after a valid start of group 2
RACE 2	All groups	As soon as possible after finish of Race 1
RACE 3	All groups	As soon as possible after finish of Race 2

At the end of the races sailors snack

Saturday 15 April 2017

See also SI 7.1.1

8:00 Coach meeting

RACE 4	Group 1 - Yellow	Warning signal 9:55 hrs
	Group 2 - Blue	Warning signal 5 minutes after a valid start of group 1
	Group 3 - Red	Warning signal 5 minutes after a valid start of group 2
RACE 5	All groups	As soon as possible after finish of Race 4
RACE 6	All groups	As soon as possible after finish of Race 5
RACE 7	All groups	As soon as possible after finish of Race 6

17:00 – 20:00 walking dinner

Sunday 16 April 2017 (final series)

See also SI 7.1.1

8:00 Coach meeting

RACE 8	Gold fleet - Yellow	Warning signal 09:55 hrs
	Silver fleet - Blue	Warning signal 5 minutes after a valid start of Gold fleet
	Bronze fleet - Red	Warning signal 5 minutes after a valid start of Silver fleet
RACE 9	All fleets	As soon as possible after finish of Race 8
RACE 10	All fleets	As soon as possible after finish of Race 9
RACE 11	All fleets	As soon as possible after finish of Race 10

At the end of the races sailors snack





Monday 17 April 2017 (final series)

8:00	Coach meeting	
RACE 12	Gold fleet - Yellow	Warning signal 09:55 hrs
	Silver fleet - Blue	Warning signal 5 minutes after a valid start of Gold fleet
	Bronze fleet - Red	Warning signal 5 minutes after a valid start of Silver fleet
RACE 13	All fleets	As soon as possible after finish of Race 12
RACE 14	All fleets	As soon as possible after finish of Race 13
At the end of the races sailors snack		

Sunday 16 April 2017 (qualifying series)

Qualifying races if fewer than five races are completed by Saturday evening (see also SI 7.1.1):

8:00	Coach meeting	
RACE 8	Group 1 - Yellow	Warning signal 9:55 hrs
	Group 2 - Blue	Warning signal 5 minutes after a valid start of group 1
	Group 3 - Red	Warning signal 5 minutes after a valid start of group 2
RACE 9	All groups	As soon as possible after finish of Race 8
RACE 10	All groups	As soon as possible after finish of Race 9
RACE 11	All groups	As soon as possible after finish of Race 10
At the end of the races sailors snack		

- 8.2 Races on each racing day are scheduled to be sailed back-to-back. However, at the discretion of the Race Committee a lunch break ashore may take place between the races. Such a break will be signalled on the finishing vessel by means of race signal flag "AP over H".
- 8.3 Each racing day may be used to start postponed or to re-start abandoned races under the restriction that no more than five (5) races will be sailed per day.
- 8.4 The order of the qualifying races scheduled for Friday, Saturday and Sunday will be maintained. If a qualifying race is not completed on its scheduled day, then racing on the next day begins with the first race that was not completed on the previous day.
- 8.5 One extra race per day may be sailed provided that the regatta will not be more than one race ahead of schedule.
- 8.6 No warning signal will be made after 15:00 hrs on Monday 17 April.





MAGIC MARINE

9. CLASS FLAGS & LYCRA'S

- 9.1 In order to visually distinguish competitors assigned to the various groups, competitors will receive upon registration at the Regatta Office a colored ribbon corresponding with the color of the group they are assigned to. This ribbon shall be attached to the top of the sprit.
- 9.2 The ribbon is only a visual aid and can never be ground for a request for redress. This changes RRS 62.1(a).
- 9.3 Official identification to which group a boat belongs is based on her sail number.
- 9.4 The Class flags are:

	<u>Ribbon:</u>	<u>Class flag:</u>
Group 1 :	Yellow	Yellow
Group 2 :	Blue	Blue
Group 3 :	Red	Red

For the final races on Sunday 16 April and Monday 17 April (see also rule 7.2):

	<u>Ribbon:</u>	<u>Class flag:</u>
Gold fleet :	Yellow	Yellow
Silver fleet :	Blue	Blue
Bronze fleet :	Red	Red

10. RACING AREA, STARTING AREA, FINISHING AREA

- 10.1. The racing area is defined as the surface of the circle overlapping by 100 metres the circle drawn through the marks of the course.
- 10.2. The starting area is defined as the area 50 metres leeward and 100 metres windward of the starting line as shown in diagram 1. The boundaries of the starting area leeward of the starting line are identified by two red round marks as shown in diagram 1.
- 10.3. The finishing area is defined as the area between the finishing line and two yellow round marks positioned 75 metres windward of the finishing line as shown in diagram 2.

11. THE COURSE

- 11.1. The length of the course depends on the wind speed and wind direction on the course area.
- 11.2. Diagram A shows the course, including the approximate angles between the legs, the order in which marks are to be passed, and the side on which each mark is to be left.
- 11.3. The course will be a trapezoid type course with a windward finish. The marks of the course will be A, B, C, D, X and Y. All marks are to be left to Port.
- 11.4. The sequence of rounding the marks will be:
START A-B-Y-X-C-D FINISH
- 11.5. The approximate compass course to the windward mark will be indicated on the Race Committee signal boat in black numbers on a yellow surface.
- 11.6. The course may be shortened at any mark. The recording committee vessel on a shortened course will not be displaying a blue flag.



12. MARKS

- 12.1 The marks A, B, C and D are ORANGE/WHITE colored cylindrical shapes. Marks X and Y are BLACK/WHITE colored cylindrical shapes.
- 12.2 The marks identifying the leeward boundaries of the starting area are red colored round shapes.
- 12.3 The marks identifying the windward boundaries of the finishing area are yellow colored round shapes.
- 12.4 The starting marks will be the race committee signal boat at the starboard end and a race committee boat at the port end. Both vessels will be flying an orange flag on their main mast.
- 12.5 The finishing marks will be a dan buoy at the port end and a race committee boat at the starboard end.
- 12.6 A race committee boat signalling a change of course is a mark as provided in SI 15.2.

13. SPARE

14. THE START

- 14.1. Races will be started by using RRS 26 with the warning signal made five (5) minutes before the starting signal.
- 14.2. The starting line will be between the main masts displaying orange flags on the starting marks.
- 14.3. At each end of the starting line an Inner Limit Mark (ILM) can be positioned. The ILM near the starboard and the port end mark will be a blue colored round shapes. Marks ILM are considered starting marks as prescribed in the preamble to RRS, part 2, section C and RRS 31. Boats shall leave the starboard end ILM to starboard and the port end ILM to port while starting.
- 14.4. The committee boat at the port end may repeat the signals of the race committee signal boat. The signals of the latter shall govern.
- 14.5. A boat starting later than four (4) minutes after her starting signal, shall be scored DNS. This changes RRS A4 and A5.
- 14.6. To alert boats that a race or sequence of races will start soon, the orange starting line flag(s) will be displayed (with one sound signal) at least five minutes before a warning signal is displayed.
- 14.7. The orange starting line flags(s) will be removed (with no sound signal) four minutes after the starting signal unless the race committee intends to make the warning signal for the next fleet to start within ten minutes of the previous start.
- 14.8. Boats whose warning signal has not been made, shall avoid the starting area until after a valid start of the preceding group. Boats whose warning signal has not been made, must stay clear from boats from the preceding start group that have just started. A boat who fails to comply with this rule may be disqualified without a hearing (this changes RRS 63.1).
- 14.9. If a start under RRS 30.3 should result in a General Recall, sail numbers of the boats identified breaking the black flag rule will be displayed on the Race Committee signal boat at starboard end or a committee vessel near the starting vessel. This changes RRS 30.3.

15. CHANGE OF THE NEXT LEG OF THE COURSE

- 15.1. To change the next leg of the course, the race committee will move the original mark (or the finishing line) to a new position.
- 15.2. Boats shall pass between the race committee vessel signalling the change of the next leg and the nearby mark, leaving the mark to port and the race committee vessel to starboard. This changes RRS 28.



16. THE FINISH

- 16.1 The finishing line will be between a staff displaying a red flag with a white square on the port end finishing mark and the mast displaying a green flag with a white square on the starboard end finishing mark.
- 16.2 After finishing and after completing any obligations under SI 18.1, boats shall clear the finishing area immediately.

17. TIME LIMIT

Boats failing to finish within fifteen (15) minutes after the finish of the first boat in their group sails the course and finishes, will be scored Did Not Finish (DNF) without a hearing. This changes RS 35 and A4 an A5.

18. PROTESTS

- 18.1. Protests forms are available at the Regatta Office. Protests and requests for redress shall be delivered there within the appropriate time limit.
- 18.2. The protest time limit is 60 minutes after the last boat of her group has finished the last race of the day or the race committee signals no more racing today, whichever is later.
- 18.3. Notices will be posted no later than 30 minutes after the protest time limit to inform competitors of hearings in which they are parties or named as witnesses. Hearings will be held in the protest room, located at the clubhouse of the Watersportvereniging Braassemermeer.
- 18.4. Notices of protests by the Race Committee or International Jury will be posted on the Notice Board to inform boats under RRS 61.1(b).
- 18.5. A list of boats that have been penalized under RRS Appendix P or have been disqualified by the International Jury will be posted.
- 18.6. Breaches of SI 9.1, 9.4, 14.9, last sentence, 16.2, 21.2, 21.3, 22, 23, 24, and 27 will not be grounds for protest or request for redress by a boat. This changes RRS 60.1(a) and 62.1(a). Penalties for these breaches may be less than disqualification if the protest committee so decides.
- 18.7. On the last scheduled day of racing a request for redress based on a protest committee decision shall be delivered no later than 30 minutes after the decision was posted. This changes RRS 62.2.
- 18.8. Decisions of the International Jury will be final in accordance with RRS 70.5.

19. SCORING

- 19.1 Four (4) races are required to be completed to constitute a series.
- 19.2 The Low Point Scoring System of Appendix A will apply. 14 races are scheduled.
- 19.3 When fewer than 5 races have been completed, a boat's series score will be the total of her race scores.
- 19.4 When 5 or more races have been completed, a boat's series score will be the total of her race scores excluding her worst score.
- 19.5 When 10 or more races have been completed, a boat's series score will be the total of her race scores excluding her worst two scores.
- 19.6 Only one (1) score can be exclude in the final series.
- 19.7 All points are carried forward into the final races.
- 19.8 As soon as possible after each race, results will be posted near the Regatta Office and on the event website.





20. SAFETY

- 20.1 It is the boat's own responsibility to decide whether or not to start.
- 20.2 When a committee vessel displays Flag "AP over H/ A" or "N over H/ A" all boats shall return to harbour via the shortest route.
- 20.3 Boats retiring shall inform the Race Committee or the Regatta Office at the first reasonable opportunity.
- 20.4 When flag V is displayed on any Race Committee boat, all coaches and support boats are permitted to enter the racing area and shall cooperate with the race committee in rescue assistance.

21. COACH AND SUPPORT BOATS

- 21.1 After the first warning signal all coach and support boats shall stay well clear of the starting, racing and finishing area until the last boat has finished. During the races there shall be no communication between competitors and non-competitors, unless a boat is in distress and requires assistance.
- 21.2 After a postponement, coach and support boats may re-enter the racing area until the new first warning signal is made, provided that the postponement applies to all groups and no groups are racing.
- 21.3 Coach and support boats must register before the first start of the first race and shall be marked with a number on a clearly visible place. This number must be obtained from the OC. The (non-refundable) registration fee will be € 35,00 and must be paid upon registration at the Information desk.
- 21.4 The RC may provide some basic information about the race on VHF channel 72.

22. TRASH DISPOSAL

Trash may be placed aboard support and Race Committee boats.

23. BEACH MASTER & OFFICIALS

Competitors shall obey the instructions of the Beach Masters and Parking Stewards. Competitors failing to obey may be excluded from participation in one or more races.

24. CLASS RULES AND MEASUREMENT CERTIFICATES

- 24.1 Spot checks on conformity with the class rules may take place at all times throughout the Regatta.
- 24.2 Each boat entered shall have a valid measurement certificate as required by her National Authority.
- 24.3 The mainsail shall show the sail number as indicated on the certificate and entry form.

25. LIABILITY AND INSURANCE

- 25.1 Participants compete at their own risk and responsibility. See RRS 4, Decision to race. The Royal Netherlands Sailing Association, the Watersportvereniging Braassemermeer and their members, the Race Committee, the International Jury, the Optimist Club Nederland or any other party involved in the organization of the Regatta cannot be held responsible for material damage or personal injury or death sustained in conjunction with or prior to, during or after the Regatta.
- 25.2 Each boat entered shall be insured with a valid third party liability insurance with a minimum cover of EUR 1,500,000.-- per incident or the equivalent in the currency of the country of registration of the boat.

26. PERSONAL FLOTATION DEVICE

All competitors shall wear a personal flotation device while afloat.





27. APPENDIX P PENALTY SYSTEM

Appendix P will apply as amended as follows:

- a) Add the following sentence to RRS P2.1: On the first protest, when penalized after she has finished, she will be given a scoring penalty of 8 points without a hearing.
- b) RRS P2.2 is changed to: When a boat is penalized a second or subsequent time during the regatta, her penalty shall be promptly to retire from the race. If she fails to take it she shall be disqualified without a hearing and her score shall not be excluded.
- c) RRS P2.3 will not apply.

28 MEDIA RIGHTS, CAMERAS AND ELECTRONIC EQUIPMENT

- 28.1 By participating in the event, competitors automatically grant to the organizing authority and their sponsors, the right in perpetuity to make, use and show, from time to time at their discretion, any motion pictures and live, taped or filmed television and other reproductions of the sailor during the period of the competition without compensation.
- 28.2 The competitors may be required for interviews at the regatta.
- 28.3 Boats may be required to carry cameras, sound equipment or positioning equipment as specified by the organizing authority.

29 RADIO COMMUNICATION

Except in an emergency a boat shall neither make radio transmissions while racing nor receive radio communication not available to all boats. This restriction also applies to mobile telephones.

30 ONBOARD CAMERAS

Onboard cameras are allowed as long as the competitor complies with the following restrictions:

- (a) Cameras cannot stream anything, anywhere; they can only be used to record videos/pictures.
- (b) Videos or pictures recorded onboard cannot be used as evidence in a hearing, either for a protest or request for redress (this changes RRS 63.6 and M7).



The Starting Area and Finishing Area

Figure 1 : Starting Area

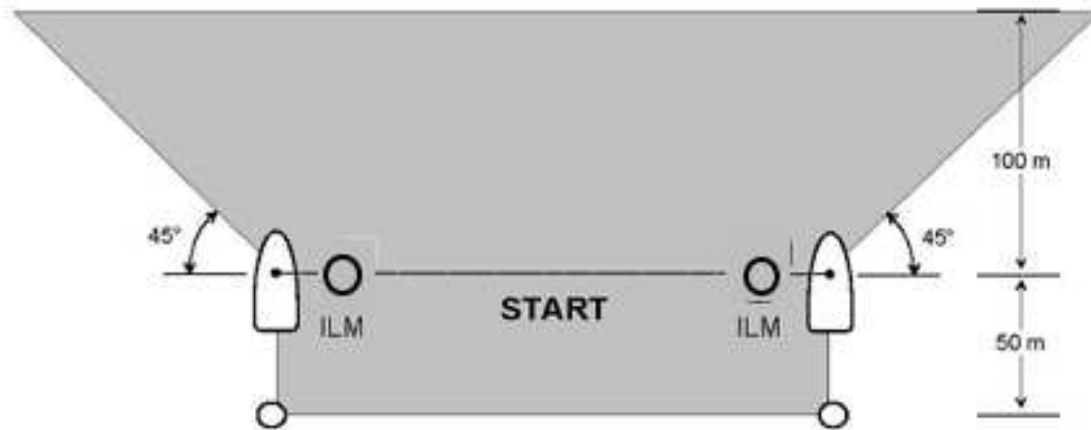
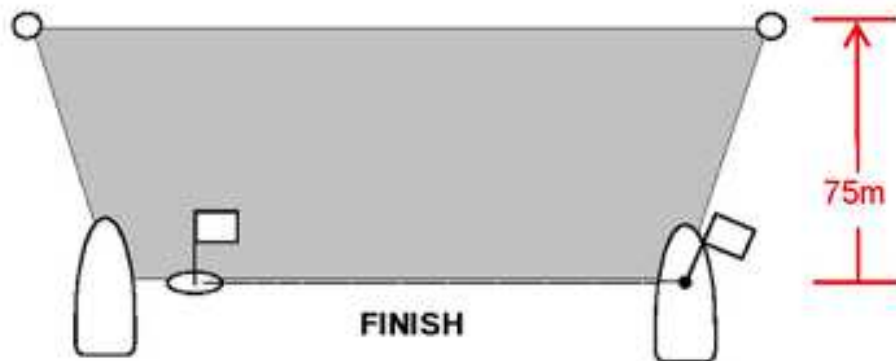
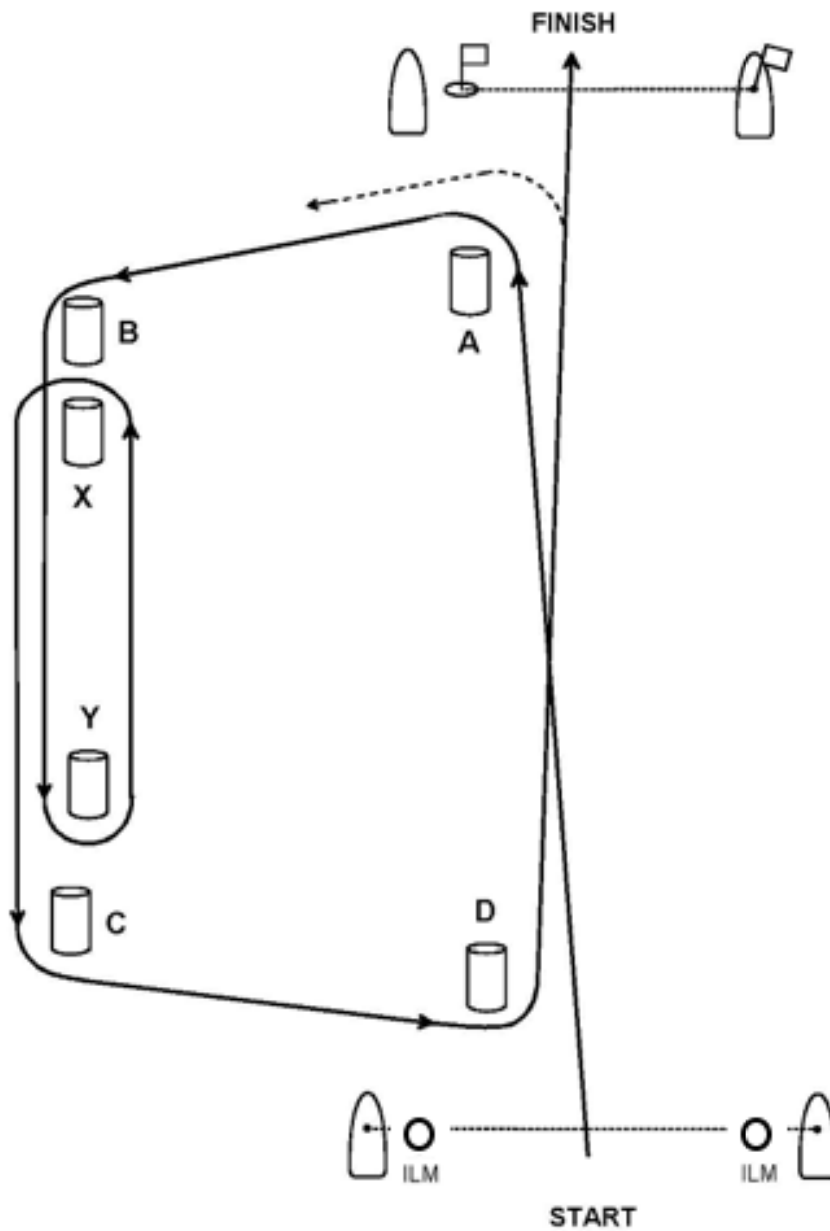

Figure 2 : Finishing Area



COURSE DIAGRAM A



The sequence of rounding the marks is:

1 LAP : START A-B-Y-X-C-D FINISH